

TYPE		P2		P1 (kW)		AMPERE		Q (m³/h - l/min)					
1~	3~	(HP)	(kW)	1~	3~	1x230 V 50 Hz	3x400 V 50 Hz	H (m)					
								0	0,6	1,2	1,8	2,4	3
INOXR 80	INOXRT 80	0,8	0,59	0,78	0,79	3,6	1,4	46,5	37	29,5	19,2	4	-
INOX 80	INOXT 80	0,8	0,59	0,79	0,79	3,7	1,4	48,5	39	32	22,4	7,6	-
INOX 100	INOXT 100	1	0,74	0,98	1	4,6	2,2	50	43	38	32	28	21

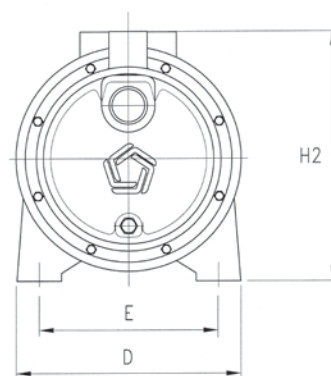

Dimensioni imballo  
Package dimensions  
Dimensions emballage  
Dimensions d'emballage

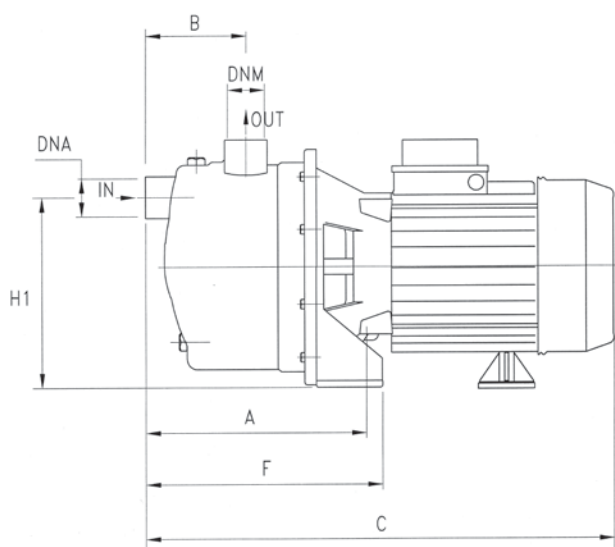
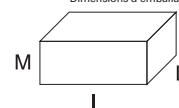

TYPE	DIMENSIONS (mm)													
	A	B	C	D	E	F	H1	H2	DNA	DNM	I	L	M	
INOXR 80	165	79	352	175	140	175	150	199	1" G	1" G	400	210	235	7.9
INOX 80	165	79	360	175	140	175	150	199	1" G	1" G	400	210	235	8.7
INOX 100	165	79	360	175	140	175	150	199	1" G	1" G	400	210	235	9.9